

Transfer or duplication of this document as well as the utilization or communication of its content are prohibited unless explicitly authorized in writing. All rights reserved for patent, utility model or design registrations. 除专利等明确标注外，其他内容均保留权利。未经许可，不得复制或传播。 本公司保留对涉及发明、实用新型和外观设计的所有权利。

未注公差/General tolerances (mm)											0.1/10			
0 ~ 3	>3 ~ 6	>6 ~ 10	>10 ~ 18	>18 ~ 30	>30 ~ 50	>50 ~ 80	>80 ~ 120	>120 ~ 180	>180 ~ 250	>250 ~ 315		>315 ~ 400	>400 ~ 500	>500
±0.12	±0.18	±0.22	±0.26	±0.31	±0.37	±0.57	±0.80	±0.93	±1.05	±1.15	±1.60	±2.20	±2.50	±2'

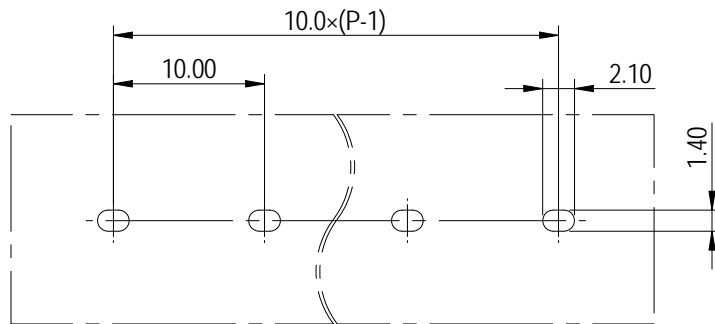
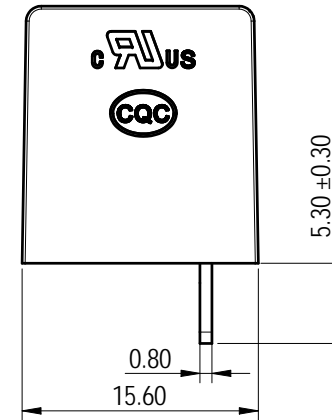
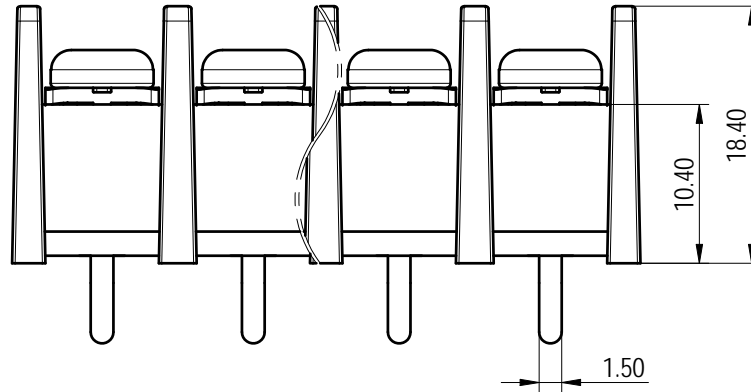
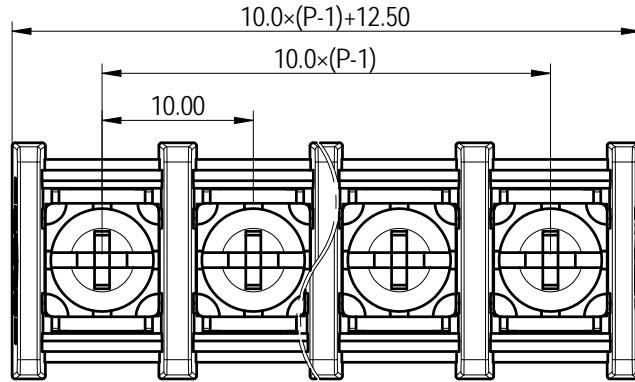

PCB LAYOUT

ITEM	NAME OF PART	MATERIAL	NOTES
3	Screw	Steel	Ni Plated
2	Pin header	Copper alloy	Sn Plated
1	Housing	PA66	UL94V-0

UL 标准/UL Standard:	B	C	D
额定电压/电流/Rated Voltage(V)/Current(A)	300/20	/	300/10
螺丝扭矩/Torque Tightening(N·m/Lb.in)	M4, 1.20/10.62		
线径范围(硬线和软线)/Wire Range(rigid and flexible)(AWG)	22~12		
间距/Pitch(mm)/线数范围/Poles	10.00/N=02~26P		
使用温度范围/Operating temperature(°C)	-40~+105		
符合RoHS环保要求/Conform to RoHS	Yes		

		MATERIAL:	SURFACE/COLOR:		
APPD: 蓝贵凡 2024.01.17		MAT NO./REV:	/ 00 MAT STATUS: 批量		
CHKD: 曹利彬 2024.01.17		NAME			
DRFT: 孙科豪 2024.01.17		DG55S-B-XXP-1Y-00A&Z(H)			
DRAWING NO.	TYPE	DRAWING STATUS	SCALE	SHEET	
200266710	CUSTOMER DRAWING	已发布	2:1	1/1	

REV	ECN	DESCRIPTION	DRFT	DATE
00				