

未注公差/General tolerances (mm)													0.1/10	
0	>3	>6	>10	>18	>30	>50	>80	>120	>180	>250	>315	>400		
~3	~6	~10	~18	~30	~50	~80	~120	~180	~250	~315	~400	~500	>500	
±0.12	±0.18	±0.22	±0.26	±0.31	±0.37	±0.57	±0.80	±0.93	±1.05	±1.15	±1.60	±2.20	±2.50	±2'

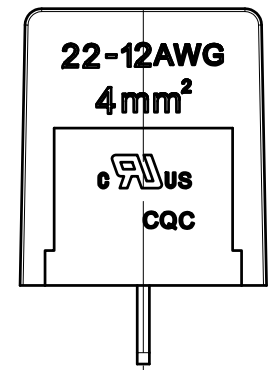

Note: The A&Z(H) in the name means: A(H) and Z(H).

ITEM	NAME OF PART	MATERIAL	NOTES
3	Screw	Steel	Ni Plated
2	Pin header	Copper alloy	Sn Plated
1	Housing	PA66	UL94V-0
UL 标准/UL Standard:			
额定电压/电涌/Rated Voltage(V)/Current(A)		B	C
螺丝扭矩/Torque Tightening(N·m/Lb.in)		300/25	/ 300/10
线径范围(硬线和软线)/Wire Range(rigid and flexible)(AWG)		M4, 1.2/10.62	
间距/Pitch(mm)/线数范围/Poles		22~12	
使用温度范围/Operating temperature(°C)		9.50/N=02~24P	
符合RoHS环保要求/Conform to RoHS		-40~+105	
		Yes	

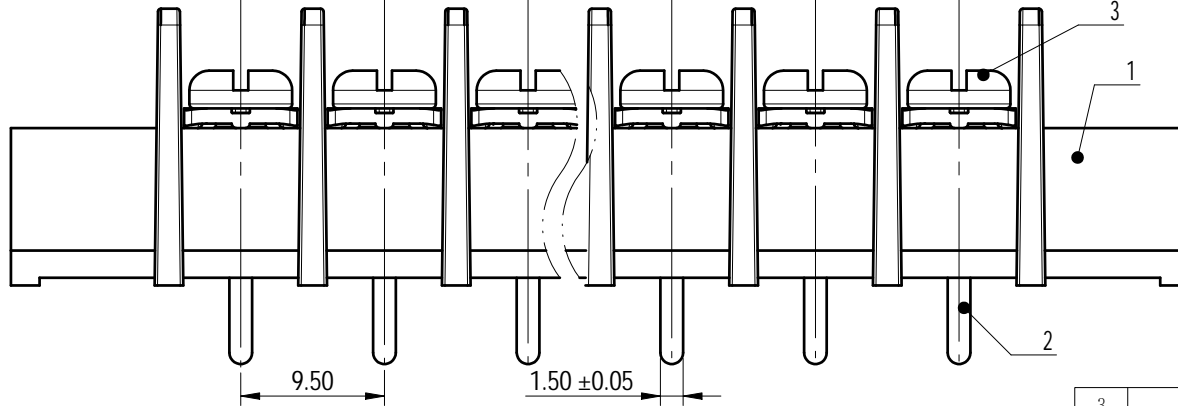
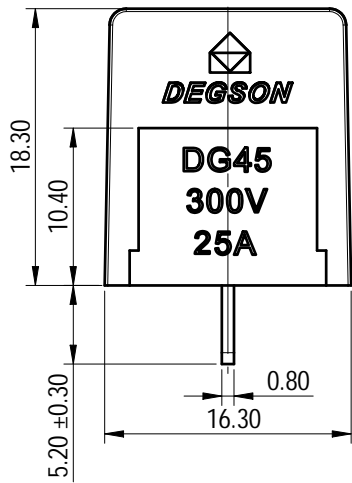
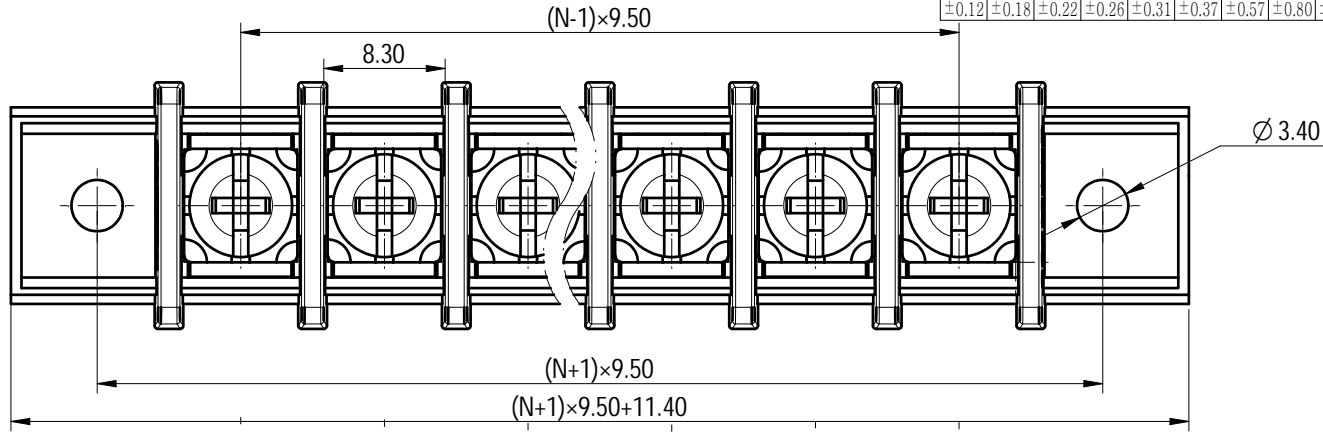
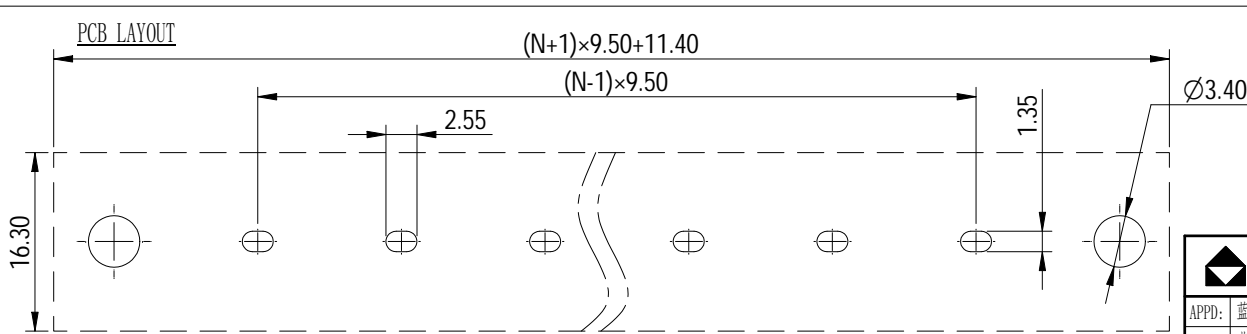

DEGSON		MATERIAL:	SURFACE/COLOR:		
APPD: 蓝贵凡 2024.04.01		MAT NO./REV: - / 00	MAT STATUS: 批量		
CHKD: 曹利彬 2024.04.01		NAME			
DRFT: 姜民洁 2024.04.01		DG45C-A-XXP-1Y-00A&Z(H)			
DRAWING NO. 200200143		TYPE	DRAWING STATUS	SCALE	SHEET
A4		CUSTOMER DRAWING	已发布	2:1	1/1

REV	ECN	DESCRIPTION	DRFT	DATE
00			姜民洁	2024.04.01

Transfer or duplication of this document as well as the utilization or communication of its content are prohibited unless authorized in writing. All rights reserved for patent. 除专利号明确标注外，其他内容均受法律保护。 未经许可，不得复制或传播。 本公司保留对涉及专利、实用新型及外观设计等权利的所有权利。